

ITEM #	PART #	NAME	MATERIAL / SIZE / DESCRIPTION	QTY.
1	90449	BLOCK, ASP GUIDE	BRASS	1
2	90490	BODY, VALVE	AL6061-T6	1
3	90471	BOLT, RAIL CLAMP		1
4	90445	BUSHING, ASP UPPER	100% TEFLON	1
5	90443	CAP, ASP V4 BASE	6061-T6 ALUMINUM	1
6	90818	CAP, MICRO SHRADER	AL2011-T3 OR AL6061-T6	1
7	90473	CLAMP, INNER RAIL		2
8	100556	CLAMP, OUTER RAIL IODINE	ANODIZED PANTONE 167c, AL7075-T6	2
9	90446	HEAD, ASP V4 CLAMP	AL7075-T6, ANODIZED BLACK	1
10	90460	HEAD, ASP V4 INNER SEAL	AL6061-T6	1
11	100560	HEAD, ASP V4 MAIN SEAL IODINE	AL6061-T6, ANODIZED PANTONE 167c	1
12	100552	LEVER, ASP CB RELEASE	AL6061-T6, ANODIZED CLEAR	1
13	90450	NUT, BASE	AL2024-T3	1
14	90475	NUT, RAIL CLAMP		1
15	90819	ORING, 1.0 X 3	BUNA N, 70A SHORE	1
16	90192	ORING, 1.5 X 18	BUNA N, 70A SHORE	2
17	90483	ORING, 1.5 X 25	BUNA N, 70A SHORE	1
18	90009	ORING, 1.5 X 26	BUNA N, 70A SHORE	1
19	90480	ORING, 1.5 X 3	BUNA N, 70A SHORE	1
20	90485	ORING, 2.5 X 14	BUNA N, 70A SHORE	1
21	90486	ORING, 2.5 X 22	BUNA N, 70A SHORE	1
22	90844	ORING, 2.6 X 12.4 J	BUNA N, 70A SHORE	1
23	100551	PIN, M3 X 24 SLOTTED SPRING	STEEL, PLATED	1
24	90448	RING, ASP GLIDE		1
25	90457	ROD, ASP V4 RELEASE	AL6061-T6	1
26	90479	SCREW, 3 X 5 PHILLIPS PANHEAD		1
27	100558	SCREW, ADJUSTER ORANGE	6061-T6 ALUMINUM, ANODIZED ORANGE PANTONE 167c	
28	90492	SCREW, TORX 3 X 6	STEEL, ZINC PLATED	2
29	90823	SEAL, ASP URETHANE VALVE	URETHANE, 65D, GREEN	1
30	90447	SHAFT, ASP COMPRESSION	AL7075-T6, ANODIZED	1
31	90474	SPRING, RAIL CLAMP		1
32	90451	SPRING, TORSION	STAINLESS WIRE	
33	90452	SPRING, VALVE	MUSIC WIRE	1
34	90453	TUBE, ASP V4 INNER	AL7050-T6 OR AL7075-T6 OR AL2014-T6 OR AL7129-T6, ANODIZED	1
35	90433	TUBE, ASP V4 OUTER 30.9	AL7050-T6 OR AL7075-T6 OR AL2014-T6, ANODIZED BLACK, 30.9	1
36	90147	VALVE, SHRADER CORE		1
37	90491	WASHER, 8 X 12		1
38	90476	WASHER, ASP V4 VALVE	AL6061-T6, 3.2 X 12 X 0.80	1
39	90455	WIPER, ASP V4 ROD	BUNA N, 70A SHORE, BLACK	1

- NOTES:
1. ADD 55ml OF 5 WT SUSPENSION OIL TO INTERNAL ASSEMBLY AND PRESSURIZE TO 70 PSI.
 2. GREASE BUSHING, GLIDE RING, COMPRESSION SHAFT AND INNER TUBE WITH HIGH LUBRICITY PETROLEUM GREASE
 3. APPLY 5 WT SUSPENSION OIL TO ROD WIPER AND ALL O-RINGS UPON ASSEMBLY

UNLESS OTHERWISE SPECIFIED DIMENSIONS ARE IN MILLIMETERS		CAD GENERATED DRAWING, DO NOT MANUALLY UPDATE		 310 BROADWAY, LAGUNA BEACH, CA 92651 TEL: (949) 464 9916 FAX: (949) 376 7010
TOLERANCES		APPROVALS	DATE	
LINEAR = ±0.1		DRAWN ML	10/11/07	BOM, JOPLIN 30.9 LEVER SEATPOST REV. B SHEET 1 OF 3
ANGULAR = ±1°		CHECKED CAW	10/11/07	
THIRD ANGLE PROJECTION		RELEASED ML	10/11/07	
		MFG ENG --	--	
		QUAL ENG --	--	SIZE PART NO. 15104 SCALE 1:2

NOTES:

1. MASTER CARTON DETAILS:
EACH MASTER CARTON WILL CONTAIN 10
UNITS.
MASTER CARTON SHOULD BE PRINTED OUTSIDE
WITH THE FOLLOWING:

- CRANKBROTHERS
- MODEL
- QTY.
- CB PART#
- PO NUMBER
- MASTER CARTON NUMBER
- COUNTRY OF ORIGIN
- NET WEIGHT
- GROSS WEIGHT
- MEAT (VOLUME)

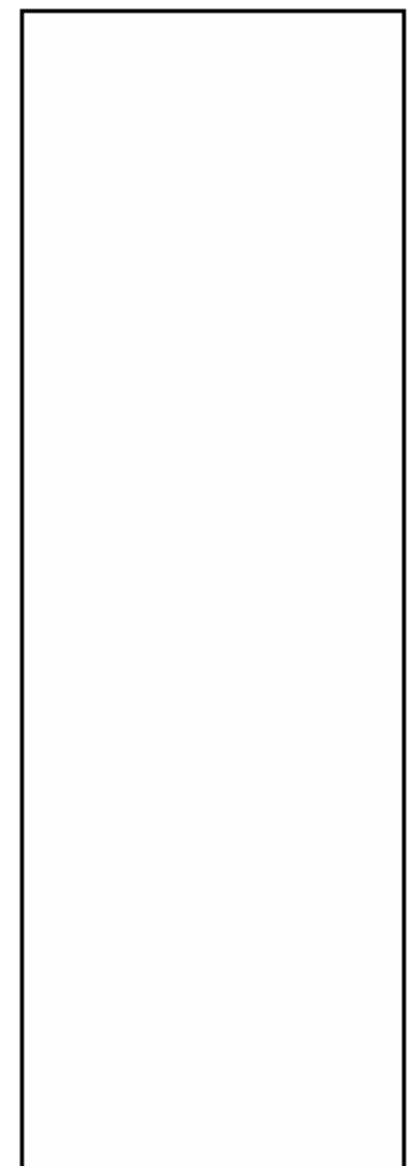
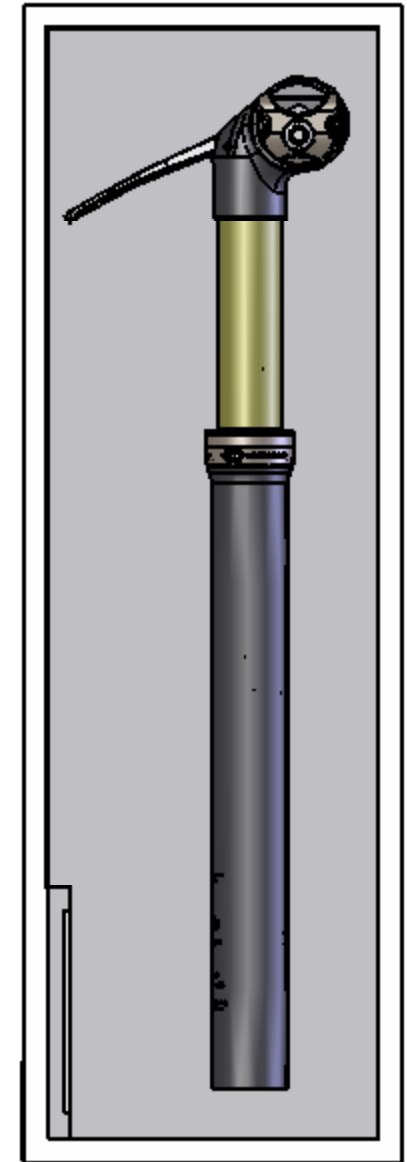
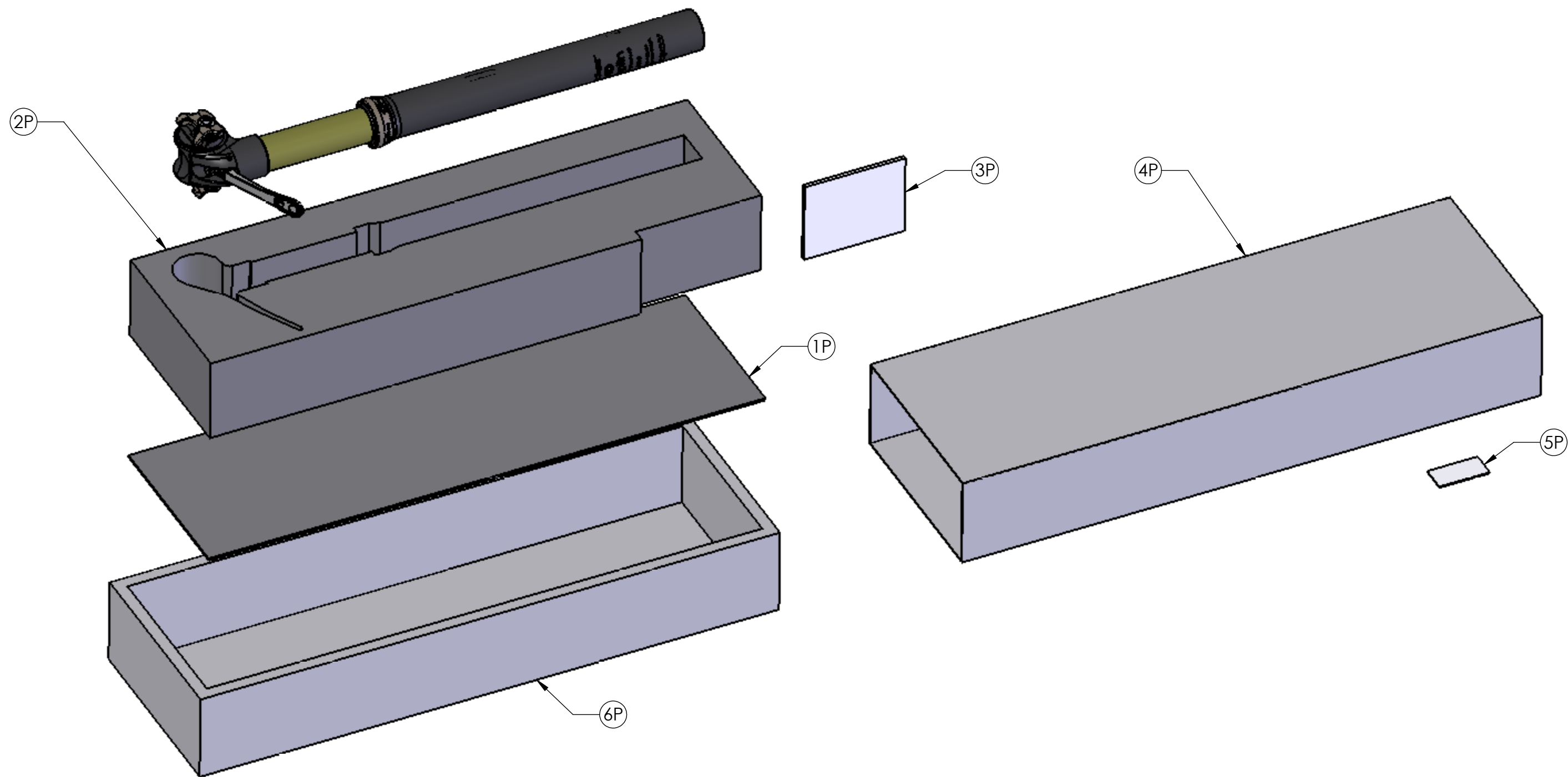

ITEM #	PART #	NAME	MATERIAL / SIZE / DESCRIPTION	QTY.
1P	15104-107	FOAM, BOTTOM JOPLIN	HD FOAM	1
2P	15104-106	FOAM, MAIN JOPLIN LEVER VERSION	LD FOAM	1
3P	15101-103	INSTRUCTIONS, JOPLIN	PAPER	1
4P	15104-105	SLEEVE, JOPLIN LEVER VERSION PACKAGING	CARDBOARD	1
5P	15104-104	STICKER, JOPLIN LEVER 30.9 UPC	PAPER	1
6P	15104-110	TRAY, JOPLIN BOX	CARDBOARD	1

ZONE	REV	DESCRIPTION	DATE	APPROVED
SH1 - F1		ADDED GREASE NOTE FOR RAIL CLAMP BOLT	10/22/2007	ML
SH1 - C8	B	ADDED MATERIAL SPECIFICATION TO OUTER RAIL CLAMP, 7075-T6		

